

Universal principles and parametric variation:
Remarks on formal linguistics and the grammar of Zulu*

Jochen Zeller
zeller@ukzn.ac.za

1. Introduction

Research on topics of an essentially African nature should be regarded as a cornerstone of learning at an African university. At the same time, this research must avoid becoming insular and parochial. The study of the indigenous languages spoken in South Africa is a good example of scholarship which has a strong local focus at the same time as having relevance for a broader academic community, with the potential to inform and shape the design of linguistic theory. In this article, I want to offer an introduction to the research conducted at the Department of Linguistics in the School of Languages, Literature and Linguistics at the University of KwaZulu-Natal. The exposition draws from my area of expertise: formal linguistics (more specifically, theoretical syntax), and from my area of research: the grammar of Bantu languages (more specifically, the syntax of Zulu¹).

Formal linguistics has a somewhat anomalous status in a faculty of human and social sciences. On the one hand, linguistics is the scientific study of human language and therefore seems to have a natural place among the disciplines in the humanities. On the other hand, formal linguists do not consider language to be first and foremost a social construct, but rather regard it as a cognitive system whose properties are best understood when studied from a strictly analytical perspective. With respect to its methodology, formal linguistics has therefore more in common with mathematics or computer science than with, say, creative arts or literary studies.

In the discussion that follows, I introduce some of the methods characteristic of the field of formal syntax, and show how they are applied to the study of natural languages such as English or Zulu. In section 2, I illustrate some of the main concepts of theoretical linguistics, such as the idea of language as a “mental organ”, which implies that fundamental properties of language are innate, and therefore universal. I also discuss Chomsky’s theory of generative grammar and its most contemporary version, the syntactic model known as the “Minimalist Program”. I then demonstrate in section 3 that this theoretical framework yields interesting results when used to examine the grammatical properties of a Bantu language like Zulu. Finally, section 4 shows that, in turn, the empirical properties of Zulu have wider theoretical implications for the way non-African languages are analysed in the Minimalist Program.

2. Aspects of formal linguistics

2.1 Knowledge of Language and Universal Grammar

One of the major aims of modern linguistic theory is to develop an understanding of the principles that characterise the ability to speak/sign and understand a language. This ability is rooted in the

* I thank Dori Posel and Ben Murrell for valuable comments.

¹ I refer to languages by their English names in this article; therefore, I have omitted the noun class prefix and use the term “Zulu” instead of “isiZulu”.

structure of every healthy human mind; language is a cognitive system, and it is the task of the linguist to investigate the nature of this system and to develop a theory which explains its properties.

The mentally represented knowledge of language is called a *grammar*. In a broad sense, “grammar” refers to all aspects of linguistic competence: phonetics and phonology (the sounds and sound systems of language), morphology and syntax (the structural properties of words and phrases), and semantics (the principles of meaning). However, the term grammar is often construed more narrowly, as that aspect of the language faculty that is concerned primarily with linguistic structures.

One of the most surprising facts about language is that children acquire it so quickly and easily. Without any explicit instruction, a child learns how to master the complex rules of the grammar of her mother tongue within the first four or five years of her life. This fact is even more surprising given that the linguistic data that provide the input for language acquisition are typically impoverished and limited, and therefore do not explain the rich, intricate and often subtle aspects of the linguistic competence one has acquired as a native speaker. We simply know much more about our language than we can possibly have learned on the basis of the linguistic evidence we were exposed to during language acquisition.

For example, the linguistic data do not provide any information about the kinds of sentences which *cannot* be formed in a language. Consider (1) and (2). Although (1a) and (2a) are very similar in meaning, only (1a) allows the formation of a question such as (1b) (as is common practice in linguistics, I have marked ungrammatical expressions with an asterisk):

- (1) a. John ate bread with cheese.
b. What did John eat bread with?
- (2) a. John ate bread and cheese.
b. *What did John eat bread and?

All speakers of English, including young children, “know” that (2b) is not a well-formed question (although they might not be consciously aware of this knowledge). However, English speakers have not been taught that (2b) is ungrammatical. The linguistic data on the basis of which they have acquired their language do not provide “negative evidence” – when a mother speaks to her child, she does not produce ungrammatical sentences, together with a little asterisk which would mark them as ungrammatical. But, if there is no negative evidence, how do speakers acquire a grammar which allows the formation of the sentence in (1b), yet excludes sentences such as (2b)? And why do all English speakers share this knowledge of their language, regardless of their social background or intellectual abilities?

The answer to these questions that was provided by the linguist and political analyst Noam Chomsky five decades ago is that certain aspects of our linguistic competence are not derived from the input data, but are determined by an innate system of linguistic rules and principles that is part of the genetic endowment of all human beings. This innate set of linguistic rules is called *Universal Grammar* (UG). The theory of UG maintains that basic rules of natural languages are biologically determined, which explains why children can acquire a language so swiftly and effortlessly, despite the limitations of the input data. (For example, questions such as (2b) are impossible in all languages, and the rule that excludes such questions, called the “Coordinate Structure Constraint” by Ross (1967), is thus a good candidate for a UG-rule.) At the same time, differences between the grammars of natural languages are explained by so-called *parameters*: the principles of UG must include aspects which are unspecified at the initial stage of language, but whose values are set in the course of language acquisition, on the basis of the available data. (An example of such a parameter is discussed in section 3.)

The idea of a UG implies that the grammars of all human languages have certain fundamental properties in common, viz. those determined by the rules and principles of UG. By studying and comparing the

grammars of natural languages, linguists try to reveal the essence of UG and develop a theory about our linguistic competence which explains not only their differences and similarities, but also the mechanisms of language acquisition.

2.2 Sentence structure and formal syntax

Since the rules of grammar determine what constitutes a well-formed sentence in a language, grammar is sometimes viewed as “generating” these grammatical sentences. This view has led to the theory of “generative grammar”, which was introduced by Noam Chomsky in the mid 1950s. Generative grammar is often used as the cover-term for different syntactic theories and frameworks that have emerged within the Chomskyan tradition (see Wasow 2001 for a useful discussion of the term). The generative approach has been developed and elaborated by numerous linguists over the last five decades, and has constantly been shaped by groundbreaking new ideas proposed by Chomsky himself (Chomsky 1965, 1970, 1977, 1981, 1986a, 1995).

The syntactic rules of grammar generate sentences by combining words to form phrases, and phrases to form sentences. For example, if a noun like *boy* combines with the definite article *the* (also called a *determiner*), we derive the phrase *the boy*. The major grammatical properties and the basic meaning of this phrase are determined by the noun *boy*;² therefore, the phrase is called a *noun phrase* (NP). The noun *boy* is called the *head* of this NP.

In theoretical syntax, the structure of phrases is schematically represented through upside-down tree diagrams, which illustrate the relations between the constituents that make up the phrase. The tree diagram for the NP *the boy* is given in (3):

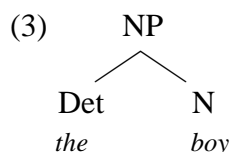

(3) is a graphic representation of the fact that the NP *the boy* is a combination of the determiner *the* and the noun *boy*.

A phrase such as the NP in (3) can itself be a constituent of a larger phrase. For example, if we combine the NP *the boy* with a verb like *kissed*, we derive another phrase, *kissed the boy*, which includes the NP and the verb as its parts. Since the basic character of this phrase is determined by the verb,³ it is called a *verb phrase* (VP), and the verb *kissed* is the head of this VP. Its structure is represented by the tree in (4):

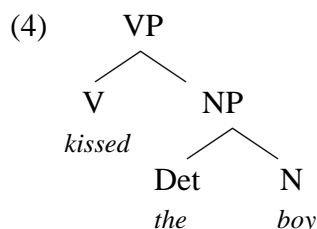

² For example, since the noun *boy* is singular, the whole phrase is singular and therefore requires a singular verb when used as the subject of a sentence: we therefore say: *The boy smokes*, not: **The boy smoke*.

³ For example, the verb determines the core meaning of the phrase: *kissed the boy* refers to a kissing-event, which is further specified by the object *the boy*.

The mechanisms that derive (3) and (4) also explain the formation of *sentences* (S). In order to derive a sentence like *The girl kissed the boy*, we only have to combine the VP in (4) with another NP:

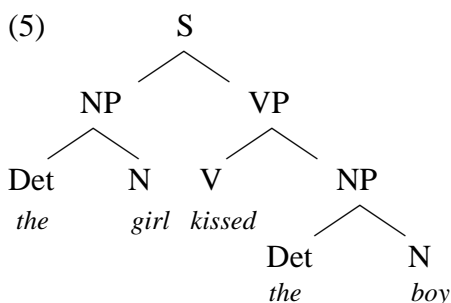

The NP *the girl* in (5) is called the *subject* of the sentence, and the VP is the *predicate*. The NP which combines with the verb inside the VP to form the predicate is called the *object*. Every sentence must include a subject and a predicate in order to be well-formed, but whether or not a sentence includes an object depends on the properties of the verb: a transitive verb like *kiss* requires an object, but an intransitive verb like *work* does not.

An important advantage of tree diagrams is that they represent the *hierarchical* relations between the constituents of a phrase or sentence. The different nodes of the tree in (5), which represent its constituents, are located on different levels. The topmost level is the sentence node S. Immediately below S, on the second level, are the subject-NP and the VP-predicate; the third level consists of the nodes Det, N, V and NP, and so on. On the basis of diagrams such as (5), the hierarchical relations between nodes in a tree can now be formally described. For example, the basic relation of *dominance* can be defined as in (6) ((6) is from an introductory syntax textbook, hence its unceremonious wording):

(6) *Dominance* (see Carnie 2002: 68)

Node α dominates node β if and only if α is higher up in the tree than β and if you can trace a line from α to β going only downwards.

According to (6), S dominates all other nodes in the tree; the subject dominates Det and N; the VP dominates the verb, the NP-object, and Det and N below the NP-object node, etc.

There are other hierarchical relations which are not captured by the notion of dominance. For example, although the subject-NP is located on a higher level in the tree in (5) than the object-NP, it does not dominate the object. Therefore, in order to express the asymmetric structural relation between the subject and the object, another formal definition is needed, which is given in (7):

(7) *c-command* (see Chomsky 1986b: 8)

α c-commands β if and only if α does not dominate β and every γ that dominates α dominates β .

If we take α to be the subject and β to be the object, then it follows that the subject c-commands the object: the subject does not dominate the object, and every γ that dominates the subject also dominates the object (there is only one such γ in (5), the S-node). Notice that the reverse does not hold: the object NP does *not* c-command the subject, since it is dominated by a node which does not dominate the subject (the VP). Therefore, the syntactic relation between subjects and objects is correctly described as asymmetric.

Many of the laws that govern the way sentences are formed in the world's languages are based on hierarchical relations between constituents, and c-command is one of the most important of these. Hierarchical relations are not obviously revealed by the linear order of words in written or spoken language. Providing structural analyses of sentences (in the form of tree diagrams, or comparable formal representations) is therefore essential for an understanding of the (universal) rules and principles of grammar.

Let me illustrate the importance of hierarchical relations by means of an example. A grammatical phenomenon which is determined by a rule based on the c-command relation concerns the distribution of so-called reflexive pronouns such as *herself*, *themselves*, *myself* etc. Consider the sentence in (8):

(8) This man loves himself.

In this sentence, the subject is the NP *this man*, and the object is the reflexive pronoun *himself*. Reflexive pronouns cannot appear in isolation (compare **Himself worked*); their reference must be determined by another NP in the same sentence, called the *antecedent*. In (8), the reflexive pronoun is interpreted as coreferential with the subject-NP: *himself* in (8) refers to whoever we mean by the NP *this man*.

What is the structural relation between a reflexive pronoun and its antecedent? In order to uncover the rules which determine possible syntactic configurations in a language, linguists rely on so-called *grammaticality judgements* provided by native speakers of this language. For example, all English speakers will agree that (8) is grammatical, but that (9) is ungrammatical, which shows that not every NP in a sentence qualifies as a possible antecedent for a reflexive pronoun:

(9) *Himself loves this man.

In (9), the role of the two NPs in (8) has been reversed; *himself* is now the subject, and the NP *this man* is the object. The ungrammaticality of (9) suggests that an object-NP cannot function as the antecedent of a reflexive pronoun in subject position. The task of the syntactician is to determine the rule which makes the NP *this man* a possible antecedent in (8), but not in (9).

A first hypothesis would be to assume that (9) is ungrammatical because the reflexive pronoun linearly precedes the NP *this man*, and one could postulate a rule that requires reflexive pronouns to follow their antecedents. Such a rule would correctly predict (9) to be ungrammatical. However, it would also predict that (10) is grammatical, which is clearly not the case:

(10) *This man's children love himself.

In (10), the reflexive pronoun follows the NP *this man's*, as is required by our hypothetical rule – but the sentence is nevertheless ungrammatical. The reflexive and the NP cannot be coreferential; (10) cannot mean that the children of the man love their father. In order to express this meaning in English, a different kind of object is required:

(11) This man's children love him.

In order to express coreference between the NP *this man's* and the object, a so-called “full” pronoun must be used; a reflexive pronoun is not possible. But how can we capture the syntactic difference between (8) and (10), which explains the difference in grammaticality? The tree diagram for (10) provides an answer:

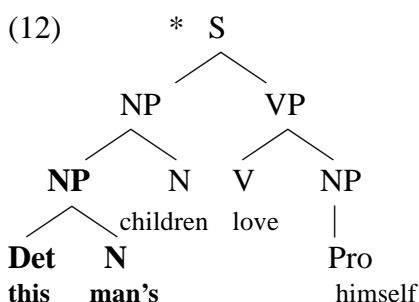

The diagram in (12) shows that, in contrast to (8), the possessor NP *this man's* (in bold) is not the subject of the sentence, but only *part of* the complex subject-NP *this man's children*; it occupies the same position inside the subject-NP that is occupied by the determiner in the example (5) above. Consequently, in terms of the definition in (7), the NP *this man's* does not c-command the object NP *himself*: the lowest branching node which dominates *this man's* is the subject-NP-node, which does not dominate the object. Therefore, what the ungrammatical examples in (9) and (10) have in common (and what distinguishes them from the grammatical example in (8)) is that in both examples, the potential antecedent does *not c-command* the reflexive pronoun.

Thus, the syntactic rule that determines the distribution of reflexive pronouns in a sentence must include the requirement that there be an antecedent that c-commands the reflexive pronoun.⁴ The linear order of antecedent and reflexive pronoun is relevant only in so far as it often (but not necessarily) reflects the hierarchical relation between constituents.⁵ Since the relation between reflexives and their antecedents is governed by c-command in all natural languages, this aspect of grammar is universal and is hence part of UG. (I return to the distribution and interpretation of reflexive pronouns in section 4.)

So far, I have looked at nouns and verbs and their phrasal projections NP and VP. Nouns and verbs belong to the so-called *content words* of a language, also called *lexical categories*. Other lexical categories are prepositions (words like *in, out, on, of, with, about, by* etc.), adjectives (*small, slow, red, intelligent, African*), and adverbs (*slowly, intelligently*). In the examples above, we saw that nouns and verbs can be the heads of corresponding phrases like NPs and VPs. Not surprisingly, prepositions, adjectives and adverbs can also build phrases. The following sentences provide examples of verbs combining with prepositional phrases (PPs), adjective phrases (APs) and adverb phrases (AdvPs):

- (13) a. Ann comes [from Ipanema].
 b. Ann is [extremely pretty].
 c. Ann writes [very slowly].

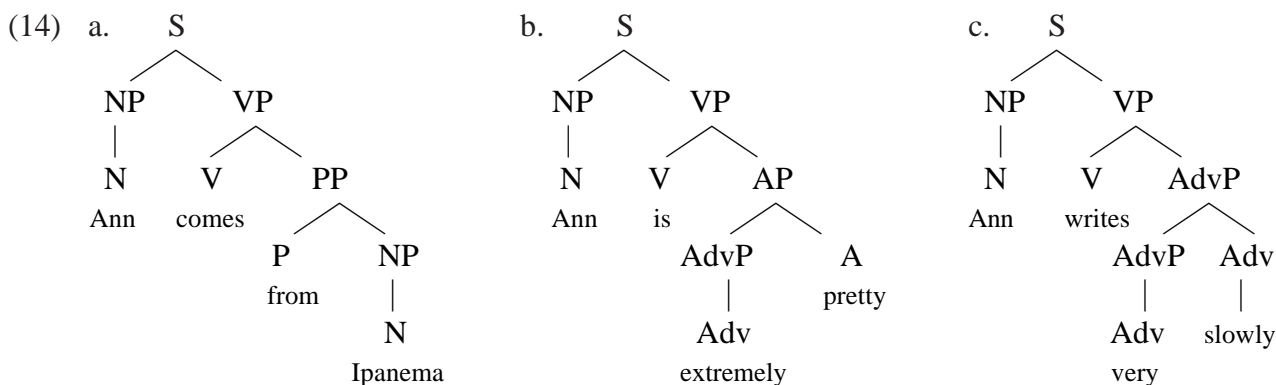

The basic aspects of the structures in (14a-c) mirror those of the phrases and sentences discussed above. All sentences in (14) are made up of a subject-NP and a VP-predicate, and each phrasal projection includes a head. The main difference is that, whereas the verb *kissed* in (5) combines with an NP-object, the verbs in (14) combine with a PP, an AP and an AdvP respectively.

⁴ Therefore, the subject-NP *this man's children* is a possible antecedent for the reflexive pronoun from a structural point of view, since it c-commands the latter. However, this NP does not match the number features of the reflexive pronoun and therefore also fails to be an antecedent for *himself* (compare, however, *this man's children love themselves*).

⁵ However, see Kayne (1994) for the claim that linear order is directly (and universally) determined by asymmetric c-command.

The same kind of phrase can also combine with words belonging to different categories. For example, (14b) and (14c) show that an AdvP can combine with an adjective, a verb, and even with another adverb. The occurrence of NPs, PPs and APs is also not restricted to a position inside the VP. We already saw in (12) above that an NP like *this man's* can be part of another NP; (15) shows that PPs and APs can appear inside NPs as well:

- (15) a. [The girl [from Ipanema]] kissed the boy.
 b. [The [extremely pretty] girl] kissed the boy.

In (15a-b), the subject-NPs *the girl from Ipanema* and *the extremely pretty girl* include a PP and an AP respectively. (Since adverbs modify only adverbs, adjectives and verbs, AdvPs are not found inside NPs, however.)

The trees in (5) and (14) show that verbs can combine with all types of phrasal projections. The largest phrase is the sentence S (although it is not clear what the head of this phrase would be, a problem to which I return in section 2.3). It is therefore not surprising that we also find verbs which can combine with full sentences:

- (16) The girl thought *Ann knew Mary*.

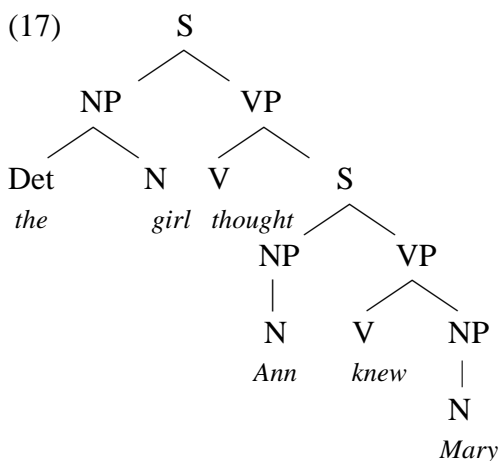

The tree diagram in (17) represents an important property of grammar which is known as *recursivity*. A function is recursive if the output of its application can be used again as its input, so that the procedure is circular and can be repeated indefinitely. The sentence in (16) is generated by a recursive set of grammatical rules: one rule determines that the sentence consists of an NP and a VP, and another rule states that a VP can be generated by combining a verb and a sentence – at which stage we can apply the first rule again, according to which the structure of the (embedded) sentence consists of an NP and a VP. Note that we could also have applied the VP-rule (which combines the verb and a sentence) for a second time, i.e. instead of combining the embedded verb *knew* with an NP, as in (16), we could have added another sentence, deriving an even more complex sentence such as (18):

- (18) The girl thought *Ann knew Mary was sick*.

The fact that syntactic rules are recursive has a very important consequence: there is no limit to the length of sentences that we can form in a language, which implies that there is also no limit to *the number of* sentences that a grammar can generate. Thus, recursivity explains the so-called *creative aspect of language use*, i.e. the fact that we can produce and understand infinitely many sentences in our language, despite the fact that the number of words in our language is finite. This unlimited generative capacity is a property of the grammars of all natural languages; recursivity is a universal aspect of our linguistic competence, and therefore also part of UG.

2.3 Syntactic structures in the Minimalist Program

The simple tree diagrams provided in section 2.2 give a basic idea of the way structural relations are represented in formal linguistics. However, in more advanced generative syntactic theory, things are a bit more complex. In the contemporary version of generative grammar called the *Minimalist Program* (Chomsky 1995, 2000, 2001), the architecture of a sentence looks like this:⁶

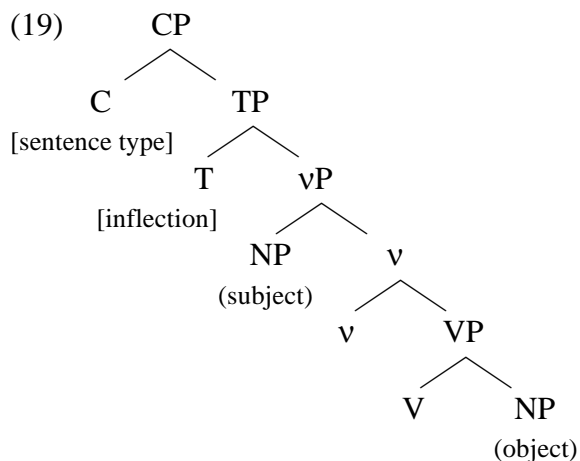

A thorough discussion of every theoretical aspect of the representation in (19) is beyond the scope of this overview article. Nevertheless, the following remarks are intended to shed some light on the intuitions behind the structure depicted here.

The tree in (19) is built according to the same fundamental principles that were also observed in the representations discussed in section 2.2: words combine with other words to form phrases, and words and phrases combine to form the sentence. One important idea that led to the articulated structural description in (19) is that not only lexical categories (i.e. words such as nouns, verbs and prepositions), but also the feature specifications of so-called *functional* categories, can build phrases and participate in the formation of syntactic structures. Functional categories, which may be represented by function words such as determiners, auxiliaries or conjunctions, establish grammatical properties of phrases and sentences, such as case, tense or sentence type. The three functional categories that are part of the structure in (19) are *v*, T and C.

The functional head *v* represents the basic structural relation between the subject-NP and the VP-predicate.⁷ Recall that the S-node in the representations discussed in section 2.2 seemed to be the only phrase without a head. This problem is avoided in the structure in (19), where the constituent which dominates both the subject and the predicate is the *vP*, which is a projection of the head *v*.

However, *vP* is not yet a complete sentence: it needs to be specified for tense (past, present, future etc.), and sentence type (interrogative, declarative, imperative), and this is the function of the two functional categories T and C, which determine the relevant grammatical properties through their respective feature specifications. The function words that may realise the functional category T (for tense) are modal verbs and auxiliaries, which are needed for the formation of certain tense forms in English, such as the future or the present perfect. The C-position may be filled with conjunctions (also called complementisers), which specify the sentence type of embedded sentences in English. For example, an embedded declarative sentence such as the one in italics in (20a) may be introduced by the complementiser *that*, while the indirect question in (20b) includes the complementiser *if*:

⁶ For the sake of clarity, I have taken the liberty to simplify the discussion in various places in this section, even if this simplification occasionally constitutes a departure from some of the standard views held in the Minimalist Program.

⁷ The head *v*, which is also called a “light verb”, has a number of other important functions in the Minimalist Program which I cannot discuss here.

- (20) a. I saw *that* John has bought this book.
 b. I wonder *if* John has bought this book.

In (21), the embedded sentence in (20a) is represented through a CP that is combined with the verb *saw* of the main clause (also called the matrix verb) to form the main clause VP-predicate:

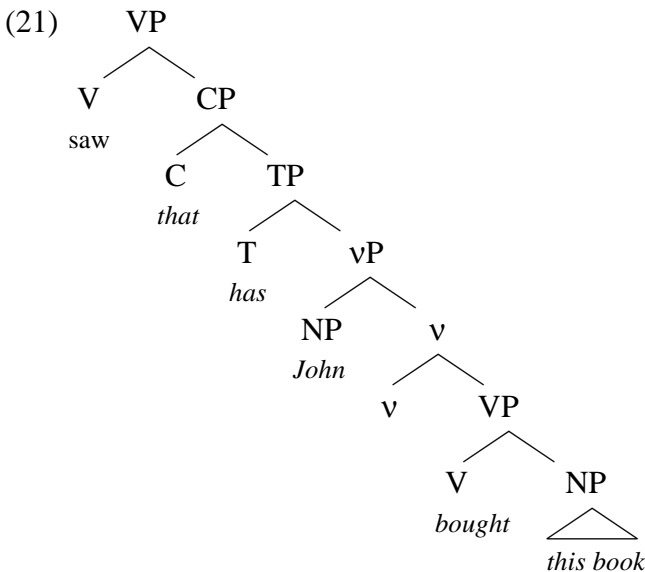

(21) illustrates that the position of the complementiser *that* is C, while the auxiliary *has* is located in T. Every complete sentence (= a sentence specified for tense and sentence type) is represented as a CP in the Minimalist Program.

There is one problem with the representation in (21): it does not yet yield the right word order. Since the subject-NP is located below the vP-node, the auxiliary precedes the subject in (21), deriving the incorrect word order **that has John bought this book*. How then is the correct word order in (20a) derived from the structure in (21)?

The important principle involved here is called *Move*. Move is an operation which changes the basic word order of a sentence by displacing certain constituents in the syntactic structure. What has happened in (20a) is that the subject-NP, which originates in the position below the vP-node, has moved into the domain of the T-head, to a position directly below the TP-node, from where it now precedes the auxiliary:

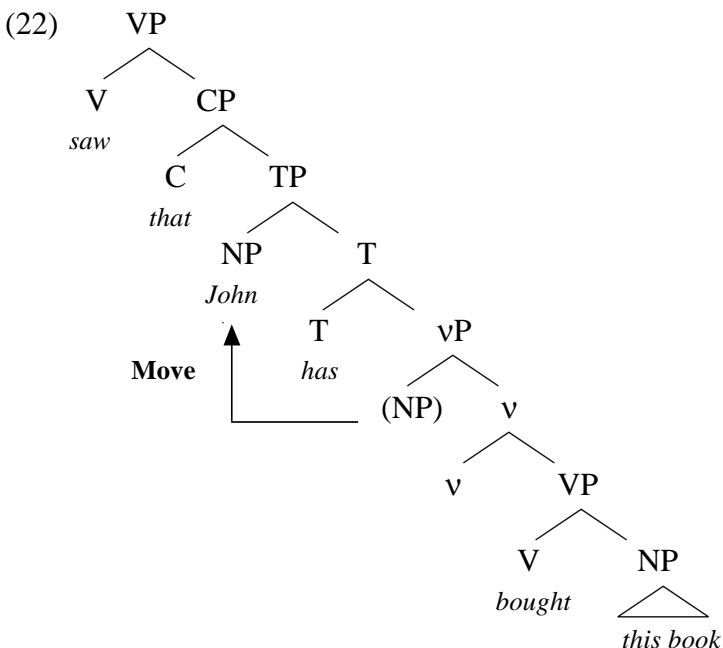

The claim that the word order Subj-Aux-Verb in English is derived by movement of the subject implies that subjects in English actually occupy two syntactic positions in the course of the derivation, one which precedes and one which follows the auxiliary. Interestingly, there is empirical evidence that supports this implication. It is possible that certain constituents that are originally part of a subject-NP do not move with the subject and therefore are stranded in the lower subject position which follows the auxiliary. Compare (23a) and (23b):

- (23) a. *All the men* have left.
 b. *The men* have *all* left.

According to the movement-hypothesis, the subject-NP *all the men* in (23a) has moved in front of the auxiliary from a position lower in the structure. In (23b), however, only the constituent *the men* precedes the auxiliary, while the quantifier *all* follows it. The disrupted constituent structure in (23b) is explained by the assumption that only one part of the subject-NP (*the men*) has moved, whereas the other part (the quantifier *all*) has been stranded in the original position of the subject inside the vP.

There is also evidence from languages other than English which shows that the structure of the sentence includes a subject position below T. Irish is a language whose basic word order is verb-subject; the finite verb always precedes the subject-NP in this language:

- (24) *Duirt mé gur phóg Máire an lucharachán.*
 said I that kissed Mary the leprechaun
 ‘I said that Mary kissed the leprechaun.’ (Irish; Carnie 2002: 207)

The Verb-Subj word order exemplified by (24) follows from the idea that in Irish, the subject-NP does not leave its base position inside the vP. Instead of the subject moving into the domain of T, it is the verb that changes its position by moving into the T-position. As a result, verbs in Irish always occupy the position that is occupied by the auxiliary in the English example in (22):⁸

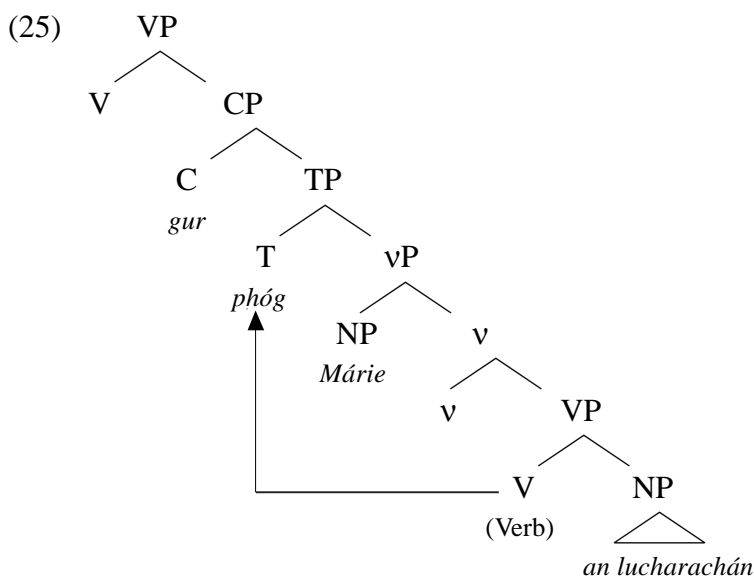

A great deal of research in modern syntactic theory is concerned with the question of what causes movement operations such as the ones exhibited in (22) and (25). In the Minimalist Program, it is assumed that it is the grammatical features of functional heads which *attract* phrases and heads,

⁸ Since the verb is a head, it can move *into* T, which is also a head position. In contrast, phrases which move into the T-domain cannot move into T directly, but must move to a position on top of T, as shown in (22).

which then have to move to a position within the domain of the attracting head. For example, both the subject in English and the verb in Irish move into the domain of the functional head T. Since T bears inflectional features, it is believed that NP-movement in English and head movement in Irish are triggered by these features.

It is sometimes argued that NPs are attracted by functional heads in order to reach a position from where they can *agree* with the grammatical features of this head. The functional head T is not only responsible for the tense specification of a sentence, it also determines agreement between the finite verb and the subject. For example, the subject-NP in (22) is specified as 3rd Person Singular, and the T-head agrees with this NP in terms of person and number (which is why the auxiliary in (22) is *has*, not *have*.) According to Chomsky (1995), the subject has moved into the domain of T in order to establish a configuration in which agreement with this functional head can be established.

A functional head can also have features which attract both heads and phrases simultaneously. This is best illustrated by the syntactic operations characteristic of the formation of questions in English. In a so-called yes-no question, the feature specification of the C-head is interrogative, and it seems that this specification triggers yet another change of word order:

(26) Have the men all left?

In (26), the quantifier *all* follows the phrase *the men*, which shows that, as in (23b), *the men* has moved to a position inside the T-domain. However, in contrast to (23b), the auxiliary *have* no longer intervenes between these two parts of the subject-NP; instead, it now precedes both subject positions. This type of subject-auxiliary inversion is found in all interrogative main clauses in English. It is explained in the Minimalist Program by the assumption that the auxiliary is attracted by a feature associated with the interrogative C-head. In the same way that verbs in Irish move into the T-position, the auxiliary in English questions moves into the C-position:

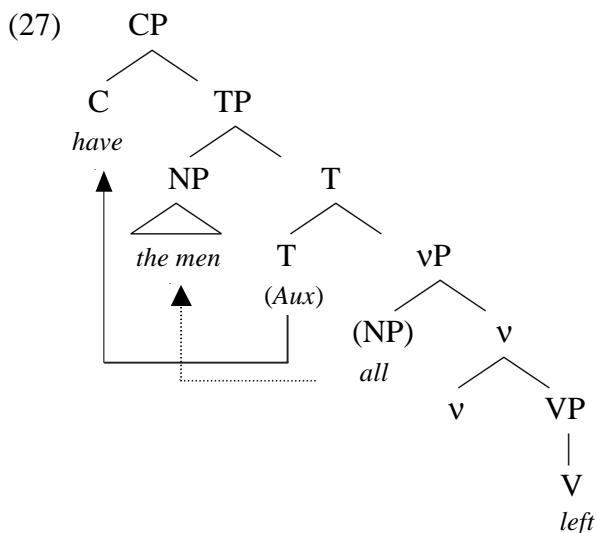

Interestingly, the interrogative feature of the C-head may also attract phrases. Compare the declarative sentence in (28a) and the so-called *wh-question* in (28b):

- (28) a. John has bought *this book*.
 b. *Which book* has John bought?

The *wh*-phrase, the NP *which book*, fulfills the same grammatical function in (28b) as the NP *this book* in (28a) – it represents the object of the verb *buy*. It should therefore be located inside the predicate. However, the *wh*-object in (28b) is the first constituent of the sentence; it appears directly in front of the auxiliary, which has moved into the C-position and therefore precedes the subject-NP

John. This word order follows from the assumption that the wh-object NP *which book* is also attracted by the interrogative feature in C and therefore has moved into the C-domain as well. Since *which book* is a phrase, it moves in the same way as subject-NPs that move into the T-domain: it lands in a position directly below the CP-node:

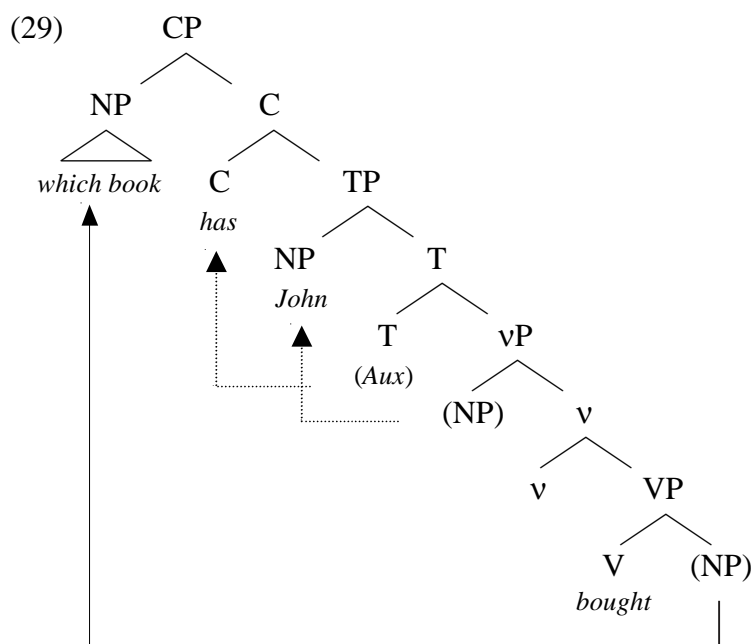

Recall that as a result of the subject being in the domain of T, T and the subject-NP agree with respect to person and number features. A similar claim can now be made with respect to (29): in English, a wh-phrase must agree with the interrogative feature in C and therefore is attracted to the domain of this functional head.

These remarks may suffice to illustrate some of the key aspects of the theory of sentence structure and movement which are pivotal to the Minimalist Program. In the next section I show what this theory reveals about the grammatical structure of Zulu.

3. Question formation in Zulu and the wh-parameter

The syntactic structure introduced in section 2.3 and the general mechanisms that determine and change the structural relations between elements in this structure are universal and assumed to be part of UG. As noted in section 2.1, syntactic differences between languages must then be explained on the basis of parameters which are associated with the universal principles of UG.

In the Minimalist Program, it is assumed that these parameters are linked to the grammatical features of functional heads. It was shown in the preceding section that these features may attract heads or phrases; these heads or phrases then move to a position in the syntactic vicinity of the attracting head. One way in which languages are parameterised is with respect to the *strength* of their grammatical features. Although UG determines that the sentence structure of all natural languages includes functional heads whose features determine grammatical properties of the sentence, it does not specify whether these features are strong enough to attract a head or a phrase in a particular language. For example, the feature of the functional head T, which triggers movement of the subject, is *strong* in English, but *weak* in Irish (therefore, the subject-NP moves into the T-domain in English, but remains inside the vP in Irish). In contrast, the feature of T that attracts the verb is strong in Irish, but weak in English (thus verb movement to T takes place in Irish, but not in English). As a result of these different parameter settings, we get two languages with fundamentally different word orders, although both are derived from the same underlying sentence structure, determined by the same principles and properties.

As was shown above, the features that are associated with an interrogative functional head C are strong in English and attract wh-phrases to the C-domain. Interestingly, Zulu (and all other Southern Bantu languages) differs from English in this respect. As the examples in (30b) and (31b) show, wh-phrases do not undergo movement in Zulu wh-questions (see Sabel & Zeller forthcoming):⁹

- (30) a. UMary u-thand-a *la* *makati*.
 Mary1a SP1a-like-Fv DEM6 cat6
 ‘Mary likes these cats.’
- b. UMary u-thand-a *ma-phi* *amakati?*
 Mary1a SP1a-like-Fv BP6-which cat6
 ‘Which cats does Mary like?’
- (31) a. UJohn u-bon-e *uMary*.
 John1a SP1a-see-PERF Mary1a
 ‘John saw Mary.’
- b. UJohn u-bon-e *bani?*
 John1a SP1a-see-PERF who1a
 ‘Who did John see?’

The word order of the declarative sentences in (30a) and (31a) is the same as in English: the subject precedes the verb and the verb precedes the object. However, the word order in the questions in (30b) and (31b) is significantly different from that of its English counterparts. An object wh-phrase in Zulu occupies exactly the same syntactic position as the corresponding non-wh-phrase; *maphi amakati*, ‘which cats’, and *bani*, ‘who’, follow the verb and have obviously not undergone movement to a sentence-initial position.

Within the syntactic framework outlined here, this difference between English and Zulu is captured by different parameter settings: whereas the feature of an interrogative C-head is strong in English, it is weak in Zulu. Therefore, wh-phrases are not attracted to the C-domain in Zulu and remain *in situ*:

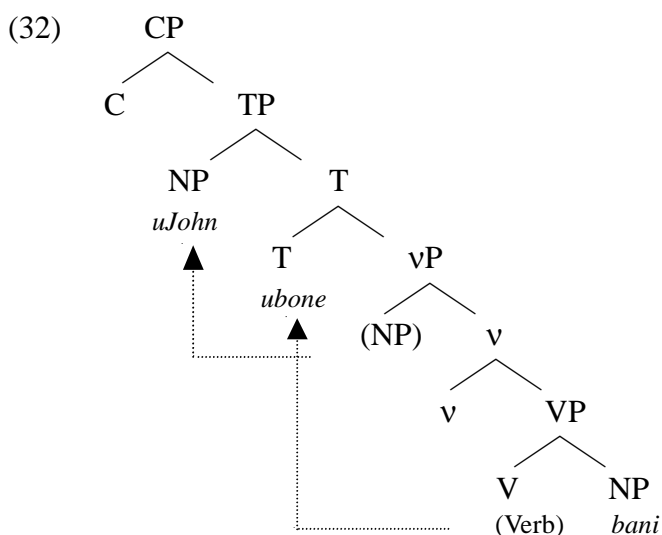

⁹ In Bantu languages, each noun belongs to a particular noun/gender class. Class membership determines agreement with demonstrative articles, verbs, adjectives, etc. In the glosses, I mark the noun classes and agreement through numbers, according to Meinhof’s (1906) numbering system of Proto-Bantu. Morphemes are glossed as follows: BP = basic prefix; COP = copula; DEM = demonstrative pronoun; FV = final vowel; IND = indicative mood; OC = object clitic; PERF = perfect tense; RC = relative concord; SP = subject prefix; SUBJ = subjunctive mood. All Zulu examples that I present in this paper have been checked by native speakers.

As (32) shows, Zulu is like English in that the inflectional property of T that attracts the subject-NP is strong. The subject therefore moves out of the vP to a position above T. In contrast to English, the feature that attracts the verb to move to T is also strong in Zulu; this parameter is therefore set to the same value as in Irish. However, Zulu differs from English (and Irish) in that the interrogative features of C are weak and do not attract wh-phrases. Consequently, Zulu is a *wh-in situ* language.

However, there is an alternative wh-construction in Zulu whose word order at first sight resembles that of English wh-questions. The question in (31b), for example, can also be expressed by (33):

- (33) *Ng-ubani* uJohn a-m-bon-ile?
 COP-who1a John1a RC1a-OC1a-see-PERF
 ‘Who did John see?’

In (33), the wh-phrase (*ng*)*ubani* occurs in sentence-initial position, and one therefore might suspect that this position is the same as the landing site of wh-movement in English. However, as is shown in Sabel & Zeller (forthcoming), the construction in (33) is actually different from the one that underlies its English translation. First, notice that the wh-phrase in this example is modified with the prefix *ng-*, which is a copular verb. Second, the morphology of the verb has changed. The verb in (33) is prefixed with a so-called *relative concord*, which is an indication that we are dealing with a relative clause construction (see Zeller 2003, 2004 for an analysis of the morphological and syntactic properties of these constructions in Southern Bantu). Therefore, (33) is what is called a *wh-cleft*, a construction which roughly corresponds to the English construction in (34):

- (34) Who was it that John saw?

Importantly, the wh-cleft in (34) does not involve movement of the wh-phrase to a position immediately below the CP-node (see Sabel & Zeller (forthcoming) for a syntactic analysis of wh-clefts). We can therefore maintain that Zulu is a true *wh-in situ* language in which wh-phrases do not move to the C-domain.

Turning now to subject questions, we make an interesting observation:

- (35) a. *UJohn* u-bon-e uMary.
 John1a SP1a-see-PERF Mary1a
 ‘John saw Mary.’
 b. **Ubani* u-bon-e uMary?
 who1a SP1a-see-PERF Mary1a
 ‘Who saw Mary?’

(35a) repeats the Zulu sentence in (31a), in which the subject-NP *uJohn* precedes the finite verb and its object. Given that Zulu is a *wh-in situ* language, one would expect that a subject question is formed as in (35b), where the subject is a wh-phrase which occupies the same position as the subject-NP in the corresponding declarative sentence in (35a). However, (35b) is ungrammatical. A subject question in Zulu cannot be formed by simply replacing the NP in subject position with a wh-phrase. Rather, the intended meaning of (35b) must be expressed by means of a cleft construction:

- (36) *Ng-ubani* o-bon-e uMary?
 COP-who1a RC1a-see-PERF Mary
 ‘Who saw Mary?’

From a purely observational point of view, the impossibility of (35b) is surprising, given that this sentence is superficially formed by the same process as (30b) and (31b): the wh-phrase occupies the

same position as the non-wh-phrase in the corresponding declarative sentence. So why is (35b) ungrammatical?

The key to the solution for the problem raised by (35b) is provided by the theoretical assumptions that underlie the view of sentence structure advocated in the Minimalist Program. Recall that according to the analysis of preverbal subjects presented in section 2.3, the subject-NP in (35b) is not really *in situ*, but in a *derived* subject position: as was shown above, subjects originate inside vP, and then move to a position in the domain of the functional head T in languages such as English and Zulu. Therefore, the subjects in both (35a) and (35b) have moved to a landing site below TP (see (32)), which means that the ungrammatical question in (35b) has *not* been formed by the same process as (30b) and (31b): only in the latter two examples is the wh-phrase really in its base position; in (35b), the wh-phrase has left this position and has moved to a position in front of the verb.

In Sabel & Zeller (forthcoming), the ungrammaticality of examples such as (35b) is explained on the basis of this insight. We argue that movement of a subject-NP to a higher subject position is ruled out in Zulu whenever this NP is a wh-phrase, but legitimate when the subject is an ordinary NP (as in (35a)). The impossibility of moving a wh-phrase into the T-domain follows from certain claims about the syntax of wh-questions in Zulu which we defend in Sabel & Zeller (forthcoming), but which I cannot discuss here, since they are based on various theoretical assumptions that I have not introduced. However, with respect to the present discussion, the important point is that this account of (35b) is possible only on the basis of the assumption that preverbal subject-NPs in Zulu have undergone movement. Without this assumption, which was empirically motivated through the analysis of languages such as English and Irish in section 2.3, a syntactic explanation for the ungrammaticality of (35b) is difficult to find, particularly in the light of the grammatical examples in (30b) and (31b).

Interestingly, with certain verbs in Zulu, there is an alternative way of forming a subject wh-question. Consider (37):

- (37) a. *UJohn* u-fik-ile.
 John1a SP1a-arrive-PERF
 ‘John arrived.’
- b. **Ubani* u-fik-ile?
 who1a SP1a-arrived-PERF
- c. *Ng-ubani* o-fik-ile?
 COP-who1a RC1a-arrived-PERF
 ‘Who arrived?’
- d. *Ku-fik-e bani?*
 LOC-arrived-PERF who1a
 ‘Who arrived?’

(37a) is a simple declarative sentence with an intransitive verb. (37b), in which the NP in the derived subject position is replaced by the wh-phrase, is ungrammatical. The corresponding wh-cleft in (37c) is well-formed. The interesting example is (37d), since here, the wh-subject-NP *follows* the verb. This is exactly the kind of *in situ*-question which we expect: the subject in (37d) has remained in its base position inside the vP. Since the verb moves to T in Zulu (as in Irish), it precedes the wh-subject in the example in (37d). Importantly, since the wh-subject has not moved, no constraints have been violated, and (37d) is grammatical.

A further interesting aspect of the construction in (37d) is the absence of a verbal prefix which would express agreement with the subject. Recall that agreement is a grammatical property of T, which may be reflected by the morphological properties of elements which occupy the T-position. In Zulu, the verb moves to T and is therefore normally inflected with a subject prefix which expresses noun class

agreement with the respective subject-NP. For example, the subject-NPs in (30a) and (31a) belong to class 1a, and consequently, the subject prefix of this class, which is *u-*, combines with the verb in T in these examples. Importantly, although the subject-NP in (37d) also belongs to class 1a, the verb is *not* inflected with *u-*. Instead, the locative prefix *ku-* is attached to the verb in (37d). This prefix is a default morpheme which takes over the position of the regular subject prefix in case no agreement between the verb and the subject can be established. This means that in (37d), where the subject has remained *in situ*, the subject-NP does not agree with T. This notable absence of agreement follows from the assumption mentioned in section 2.3 above, according to which subjects move into the domain of T in order to establish agreement with T's functional features. Zulu is a language which ordinarily requires movement to the subject position to establish this agreement; however, if this movement step does not take place for some reason (for example, because the subject is a wh-phrase), then the verb cannot agree with the subject and is hence prefixed with *ku-*.

The representation in (32) shows that fundamental aspects of Zulu grammar are characterised by the same properties that are found in genetically unrelated languages such as English or Irish: its phrase structure is based on the same elements and projections, and the positions of the subject and the verb are determined by movement operations that were independently attested in English and Irish. The properties of Zulu therefore provide strong support for the idea of a universally determined set of grammatical principles that hold for all natural languages. Differences between the grammar of Zulu and those of other languages can straightforwardly be explained by parameters whose values are determined by the linguistic data that provide the input for language acquisition.

4. Subject raising in Zulu and the subjunctive mood

In the preceding section I have shown that the theory of generative grammar provides the right tools for the theoretical study of the syntactic properties of Zulu. I now turn to an example which demonstrates that studying Zulu from this perspective can also lead to new insights into certain theoretical aspects of the Minimalist Program, which have interesting implications for the study of languages other than Zulu.

Consider the constructions in (38):

- (38) a. It seems that John is hungry.
 b. John seems to be hungry.

In both (38a) and (38b), the verb *seems* has combined with an embedded sentence, a possibility that exists because of the recursive property of language, as discussed in section 2.2. The difference between both sentences in (38) is that while the verb *seems* in (38a) combines with a *finite* sentence, the embedded sentence in (38b) is an *infinitive*. Infinitives differ from finite sentences in that their T-heads are not specified for tense and agreement features, and that they do not have overt subjects: whereas the VP *is hungry* in (38a) takes the NP *John* as its subject, the embedded sentence in (38b) seems to lack a subject and to consist only of the predicate *to be hungry*.

However, notice that from a semantic point of view, the NP *John* is the subject of the predicate *to be hungry* in (38b) as well – even though the NP appears in the subject position of the main clause, (38b) essentially means the same thing as (38a). Furthermore, it was noted in section 2.2 that every sentence must have a subject – but if infinitives are sentences, the lack of a subject is unexpected. In generative grammar, it is therefore assumed that the NP *John* is indeed the subject of the infinitive in (38b) at an initial stage of the derivation, but that the embedded subject has moved to the subject position of the matrix sentence. The tree diagram in (39) illustrates this derivation (the infinitive is not represented as a CP in (39), but as a TP, for reasons which are of no relevance for the discussion):

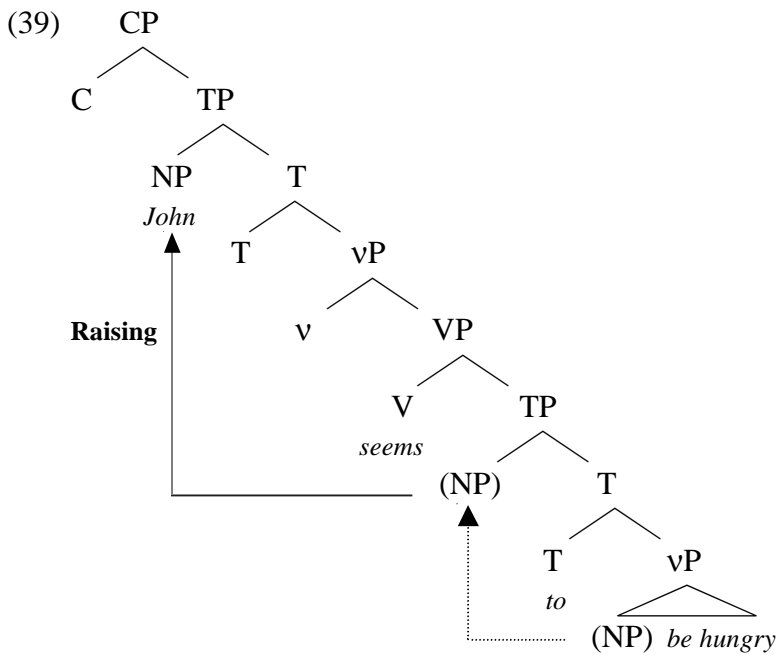

(39) shows that the NP *John* originates inside the vP of the infinitive, from where it moves to the subject position below the lower TP-node. However, *John* does not remain in this position, but moves further up and lands in the subject position of the main clause. Because of this latter movement step, (38b) is called a *raising*-construction.

On the one hand, raising is clearly required in (38b); with the subject-NP staying inside the infinitive, the construction is ungrammatical, as shown in (40a). On the other hand, raising is only possible with subjects of infinitives in English. As (40b) demonstrates, if the embedded sentence is finite, its subject cannot move to the matrix sentence:

- (40) a. *It seems John to be hungry
 b. *John seems that is hungry.

Syntacticians therefore link the possibility of raising in (38b) to the presence of the infinitive. The idea is that, due to the deficient feature specification of the infinitival T-head (= no tense and agreement features), an overt subject-NP is not licensed inside the T-domain of an infinitive and therefore must move to the subject position of a finite sentence. In contrast, if a subject-NP appears in the T-domain of a finite sentence, it is already licensed, and further movement to another T-domain is prohibited.

In the light of these assumptions, consider the Zulu examples in (41) and (42).

- (41) a. Ku-lungile ukuthi uJabu a-yek-e.
 Loc-fine that Jabu1a SP1a-resign-SUBJ
 'It's fine that Jabu should resign.'
 b. UJabu u-lungile ukuthi a-yek-e.
 Jabu1a SP1a-fine that SP1a-resign-SUBJ
 'It's fine that Jabu should resign.'
- (42) a. Ku-fanele ukuthi abantwana ba-fund-e.
 Loc-must that child2 SP2-study-SUBJ
 'It is necessary that the children study.'
 b. Abantwana ba-fanele ukuthi ba-fund-e.
 child2 SP2-must that SP2-study-SUBJ
 'The children must study.'

(Van der Spuy 2001: 244f.)

The verbs in the (a)-examples combine with finite sentences which include a subject and a predicate. The matrix verb is inflected with the default prefix *ku-* (see section 3), which suggests that no subject-NP is present in the higher T-domain of (41a) and (42a). (41a) and (42a) are therefore comparable to (38a). (The English pronoun *it*, which appears in the higher subject position in (38a), is a meaningless dummy element which is assumed to have the same function in English as the *ku-* prefix has in Zulu.)

The interesting examples are (41b) and (42b). In these sentences, the embedded subject-NPs of the (a)-examples have become the matrix subjects. This makes these examples look like raising constructions. The problem is, however, that in contrast to the English raising construction in (38b), the embedded sentences in (41b) and (42b) are not infinitives. Instead, the sentences whose subject-NPs have moved in these examples are finite, with the verbs expressing agreement with the (moved) subject-NP. But if the subject-NP has been located in the domain of a finite T-head at some stage of the derivation, then it is not clear why subject-raising is possible in (41b) and (42b), given that the corresponding English example in (40b), with raising out of a finite sentence, is ungrammatical.

A closer look at the Zulu data reveals another interesting aspect: the embedded sentences in (41) and (42) are finite, but in the *subjunctive mood*. This is an important difference between the Zulu raising constructions in (41b) and (42b) and the English example in (40b), where the embedded sentence is finite, but in the indicative (it is controversial whether present-day English has a well-defined subjunctive mood¹⁰). The explanation for the surprising grammaticality of examples such as (41b) and (42b) may now be sought in this observation. What the Zulu data suggest is that the “finiteness”-value specified by the subjunctive mood is somehow between the indicative mood of a finite sentence and an infinitive. Whereas the English examples demonstrate that subjects of infinitives *must* raise and subjects of finite sentences in the indicative *cannot* raise, the Zulu data show that raising of the subject-NPs of sentences in the subjunctive is *optional*. Both (41b) and (42b) are possible, but the corresponding sentences (41a) and (42a), in which the embedded subjects have remained inside the subordinate clause, are grammatical as well.

The observation that embedded clauses in the subjunctive mood occupy an intermediate position between finite and non-finite sentences has an interesting consequence for the study of certain phenomena which have to do with the licensing of reflexive pronouns (see section 2.2). Compare the English sentences in (43):

- (43) a. John says [that Peter shaves himself every day].
 b. John promised [to shave himself every day].

It was already noted in section 2.2 that the reflexive pronoun *himself* requires a c-commanding antecedent-NP. In (43a), both the matrix subject-NP *John* and the subject-NP of the finite embedded sentence *Peter* c-command the reflexive pronoun. However, only the NP *Peter* can function as the antecedent – a coreferential interpretation of *John* and *himself* is not possible in (43a). In contrast, although the NP *John* is also in the subject position of the matrix clause in (43b), the reflexive pronoun inside the infinitive can take this NP as its antecedent in this example. Whereas coreference between a matrix subject and a reflexive pronoun in an embedded *finite* sentence cannot be established, the matrix subject is the only possible antecedent for the reflexive pronoun in the *infinitive*.

In this light, consider now the following examples from Icelandic:

- (44) a. Jón veit [að Pétur rakar sig á hverjum degi].
 John knows that Peter shave-IND himself every day
 only: ‘John knows that Peter shaves himself (= Peter) every day.’
not: ‘John knows that Peter shaves him (= John) every day.’

¹⁰ The verb forms in expressions such as *They requested that he be punished* or *If I were you...* are sometimes considered to be realisation of the subjunctive mood in English (see e.g. Leech 1971).

- b. Jón segir [að Pétur raki sig á hverjum degi].
 John says that Peter shave-SUBJ himself every day
 both: ‘John says that Peter shaves himself (= Peter) every day.’
and: ‘John says that Peter shaves him (= John) every day.’

(Icelandic; Reuland & Everaert 2001: 649)

The Icelandic examples in (44) show constructions with embedded sentences which include the reflexive pronoun *sig*, ‘himself’. In (44a), the embedded verb is in the indicative, and coreference with the matrix subject is impossible. In this respect, (44a) mirrors the English example in (43a). In contrast, the embedded sentence in (44b) is in the subjunctive, and here, two interpretations are possible: the reflexive can be coreferential with the embedded subject, in which case (44b) means the same as (44a). However, in contrast to (44a), *sig* in (44b) can also refer to the matrix subject *John* – an interpretation which in English requires the use of the pronoun *him*. This “long-distance” relation between an embedded reflexive pronoun and a matrix subject is possible in English only when the embedded clause is an infinitive.

Again, we find that an embedded sentence in the subjunctive has properties of both finite and non-finite clauses, as far as relations between embedded elements and the main clause are concerned. Without knowledge of the Zulu data in (41) and (42), the difference between the possible interpretations of the Icelandic example (44b) and the English example in (43a) poses a problem for a theory which attempts to formulate universal principles about the distribution of reflexive pronouns in natural languages. However, the study of the Zulu raising constructions has led to the important insight that, besides finite and non-finite sentences, subjunctives represent a third type of embedded clause, which shares properties of both. In this light, the Icelandic examples can be interpreted as another manifestation of the hybrid character of embedded sentences in the subjunctive.

5. Conclusion

The framework of contemporary syntactic theory is to a large extent determined by the linguistic properties of well-studied languages such as English, German, or Japanese. The formal analysis of an under-researched African language like Zulu therefore has important implications for the theory of generative grammar, and consequently for the study of other, African and non-African, languages. Importantly, research on Zulu grammar relies on empirical linguistic data provided by mother tongue speakers of the language. The conclusion to be drawn from these facts is clear: more Zulu-speaking linguists are needed – scholars who have the theoretical skills to study Zulu grammar on the basis of their own linguistic competence in this language, without having to rely on data provided by other sources. This conclusion translates into the task of motivating more Zulu speakers to engage in the scientific study of their mother tongues. This will have fruitful consequences for our understanding of the grammatical properties of Zulu and other African languages, but also for the development of linguistic theory and the study of natural language as a universal human ability.

6. References

- Carnie, Andrew (2002). *Syntax*. Oxford: Blackwell.
 Chomsky, Noam (1965). *Aspects of the Theory of Syntax*. Cambridge.
 Chomsky, Noam (1970). Remarks on Nominalization. In: R. Jacobs and P. Rosenbaum (eds), *Readings in English Transformational Grammar*. Waltham, Mass.: Ginn and Co., 184-221.
 Chomsky, Noam (1977). On wh-movement. In: Peer Culicover, Thomas Wasow and Adrian Akmajian (eds), *Formal Syntax*. New York/San Francisco/London: Academic Press, Inc., 71-132.

- Chomsky, Noam (1981). *Lectures on Government and Binding*. Dordrecht.
- Chomsky, Noam (1986a). *Knowledge of Language*. New York.
- Chomsky, Noam (1986b). *Barriers*. Cambridge: MIT Press.
- Chomsky, Noam (1995). *The Minimalist Program*. Cambridge: MIT Press.
- Chomsky, Noam (2000). Minimalist Inquiries: the Framework. In: R. Martin, D. Michaels and J. Uriagereka (eds), *Step by Step*. Cambridge, Mass.: MIT Press, 89-155.
- Chomsky, Noam (2001). Derivation by Phase. In: Michael Kenstowicz (ed), *Ken Hale. A Life in Language*. Cambridge: MIT Press, 1-52.
- Kayne, Richard (1994). *The Antisymmetry of Syntax*. Cambridge: MIT Press.
- Leech, Geoffrey N. (1971). *Meaning and the English Verb*. London: Longman.
- Meinhof, Carl (1906). *Grundzüge einer vergleichenden Grammatik der Bantusprachen*. Berlin: Dietrich Reimer.
- Reuland, Eric and Martin Everaert (2001). Deconstructing Binding. In: Mark Baltin and Chris Collins (eds), *The Handbook of Contemporary Syntactic Theory*. Oxford: Blackwell, 634-669.
- Ross, John Robert (1967). Constraints on Variables in Syntax. PhD Thesis, MIT, Cambridge (reproduced by the Indiana University Linguistics Club 1968).
- Sabel, Joachim and Jochen Zeller (forthcoming). wh-question formation in Nguni. To appear in: John Mugane, John Hutchison and Dee Worman (eds), *African Languages and Linguistics in Broad Perspective* (selected Proceedings of the 35th Annual Conference of African Linguistics, Harvard, Cambridge). Somerville, Massachusetts: Cascadilla Press.
- Van der Spuy, Andrew (2001). Grammatical Structure and Zulu Morphology. Ph.D. thesis, University of the Witwatersrand, Johannesburg.
- Wasow, Thomas (2001). Generative Grammar. In: Mark Aronoff and Janie Rees-Miller (eds), *The Handbook of Linguistics*. Oxford: Blackwell, 295-318.
- Zeller, Jochen (2003). Word-level and phrase-level prefixes in Zulu. *Acta Linguistica Hungarica* 50/1-2, 227-244.
- Zeller, Jochen (2004). Relative clause formation in the Bantu languages of South Africa. *Southern African Linguistics and Applied Language Studies* 22/1-2, 75-93.